



Installing and Testing LightBAT™ G2 Dual-level Switching Controller and PIR Sensor

Hubbell Building Automation, Inc.
9601 Dessau Road • Building One • Suite 100
Austin, Texas 78754
512-450-1100 • 512-450-1215 Fax

CAUTION

- Read and understand these instructions before getting started.
- To prevent severe shock or electrocution always turn the power OFF at the service panel before beginning installation.
- Only personnel qualified to work with high voltage and capacitor discharge should install this unit.
- Must be installed and/or used in accordance with appropriate electrical codes and regulations.

Catalog No. Ratings (Temperature Range -35°C to 65°C unless noted)

LB1	175W Metal Halide 175W, 200W Pulse Start Metal Halide
LB2	250W, 320W, 350W, 400W Metal Halide 250W, 320W, 350W, 400W, 450W Pulse Start Metal Halide 250W High Pressure Sodium (HPS) 400W High Pressure Sodium (HPS) (Maximum operating temperature @ 55°C)
LB3	1,500W, 1,650W Metal Halide (Maximum operating temperature @ 55°C) 1,000W Metal Halide (Maximum operating temperature @ 65°C) 750W, 1000W Pulse Start Metal Halide (Maximum operating temperature @ 55°C) 600W, 1,000W High Pressure Sodium (HPS) (Max. operating temperature @ 65°C)

14. Ordering Information.

LB1 (Range 1)	LightBAT G2	HID Dual-Level Switching Controller and PIR Sensor
LB2 (Range 2)	LightBAT G2	HID Dual-Level Switching Controller and PIR Sensor
LB3 (Range 3)	LightBAT G2	HID Dual-Level Switching Controller and PIR Sensor
LB1EXTP1 (Range 1)	LightBAT G2	HID Dual-Level Switching Controller and PIR Sensor with 4 Pin Low Voltage Interface
LB2EXTP1 (Range 2)	LightBAT G2	HID Dual-Level Switching Controller and PIR Sensor with 4 Pin Low Voltage Interface
LB3EXTP1 (Range 3)	LightBAT G2	HID Dual-Level Switching Controller and PIR Sensor with 4 Pin Low Voltage Interface
LBLens 15		Lens 15, Aisle Lens, 1.5 x 2.3
LBLens 10		Lens 10, Aisle Lens, 1.0 x .23
LBLens 07		Lens 07, Aisle Lens, .70 x .23
LBLens 0806		Lens 0806, Area Lens, .80 x .60
LBLAT1		Laser Alignment Tool
LBCSR10		Cable Strain Relief, 10 pack
LBKIT1		Conversion Hardware Kit for non-MYzer Port HID Fixtures
MPC2P10		MYzer Port Connector, 10 pack
MPBP10		MYzer Port Bypass Shorting Plug, 10 pack

Replacement Parts

DC6	Power Cable, 6 foot
LBLATSW	Laser Alignment Tool on/off Switch
LBCOVER1	Capacitor and Wiring Compartment Cover
LBMOUNT1	3/4" Threaded Mounting Adapter
LBCAPWIRES	Two (2) Cap Connection Wires with Quick Disconnects
MPNAC2P100	MYzer Port Connector Nipple Adapter, 100 pack
LBFP10	G2, 4 pin EXTP1-Port Plug, 10 pack

Accessories Required:

- LB-Lens-xx, PIR sensor lens
- Dim capacitor
- LB-LAT-1, LightBAT Laser Alignment tool

Tools Required for Installation

- Phillips Screw driver
- Side cutters/diagonal
- Long nose pliers
- Slip joint pliers
- Bullet level

Site Specific Parts (Supplied by the Installer)

- 3/4" threaded pipe (metal or plastic)
- Pipe mounting hardware to ceiling or joist
- Fixture must be equipped with MYzer port connector system. If MYzer port connector system is not installed, call HBA customer service and order MYzer port retrofit kit (part number - LB-KIT-1).

HBA warrants this product for five years to be free of defects in materials and workmanship under normal and proper use from purchase date. This warranty excludes and there is disclaimed liability for labor for removal of this product or reinstallation. This warranty is void if this product is installed improperly or in an improper environment, overloaded, misused, opened, abused, or altered in any manner, or is not used under normal operating conditions or not in accordance with any labels or instructions. HBA is not liable for incidental, indirect, special, or consequential damages, including without limitation, damage to, or loss of use of, any equipment, lost sales or profits or delay or failure to perform this warranty obligation.

1. How does the LightBAT G2 work?

The LightBAT G2 is a digitally integrated HID Dual-level Switching Controller and Sensor. Energy savings is achieved by switching lamps to 50% power. When the digital PIR occupancy sensor detects motion, lamp immediately returns to bright.

Lamp power reduction is achieved by electronically switching a series dim capacitor located in the LightBAT G2. The value of this capacitor determines light levels at low power. HBA has selected capacitor values based on recommendations from lamp manufactures and NEMA (National Electrical Manufacturers Association) not to exceed 50% reduction in lamp power when operating lamp is at low power. Turning HID lamps off then immediately back on is not possible because of long lamp cool down and warm up cycles.

Upon initial power up of HID lamps, or after a power failure or phase drop out, the lamp will automatically start at full bright and remain at full bright for 15 minutes (30 minutes for lamp wattages of 750W or above) to properly warm up the lamp. Lamp can then be switched to low, after this guaranteed lamp warm up time.



2. G2 Features.

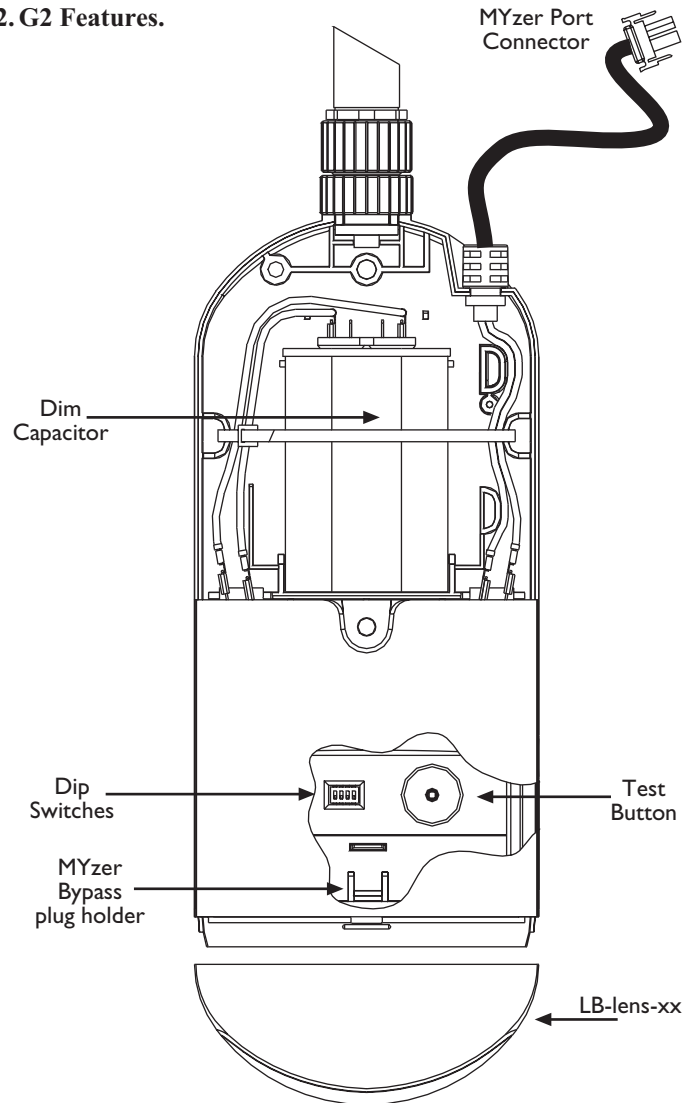

3. Dim Capacitor Selection.

Important: Dim capacitor value sets low power level. Installing wrong capacitor value may cause lamp failure or decrease energy savings.

Different dim capacitors may be required for the same lamp type depending upon ballast mfg. Fixtures already equipped with a MYzer port will have dim capacitor value and voltage on label next to the fixture connector. If capacitor value is not identified, open HID ballast housing and obtain ballast mfg., ballast part number and HID fixture capacitor value. Check the HBA website, hubbell-automation.com, for capacitor value selection table or call for technical support.

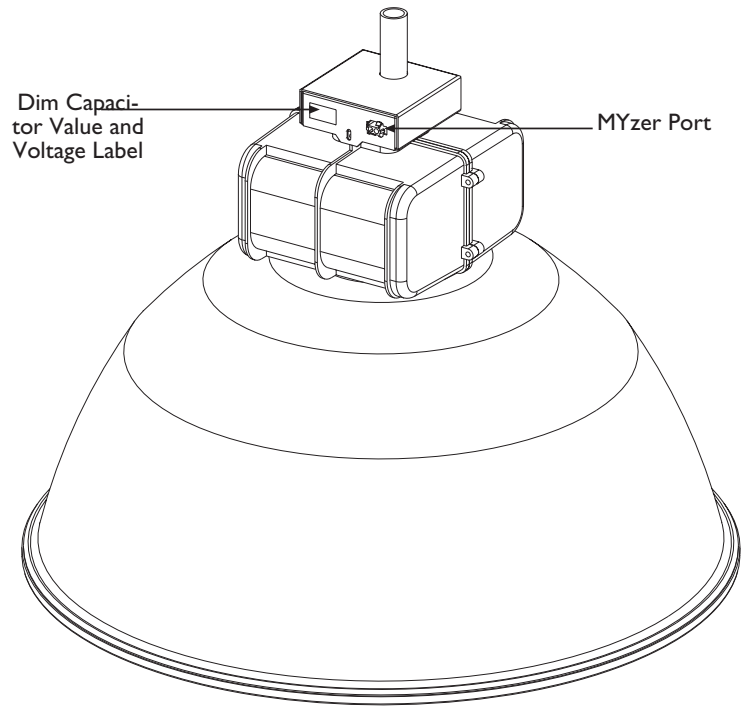

4. Capacitor Installation.

Before dim capacitor can be installed, removal of support tabs in the LightBAT G2 may be required. See “Support Tab Removal Table.”

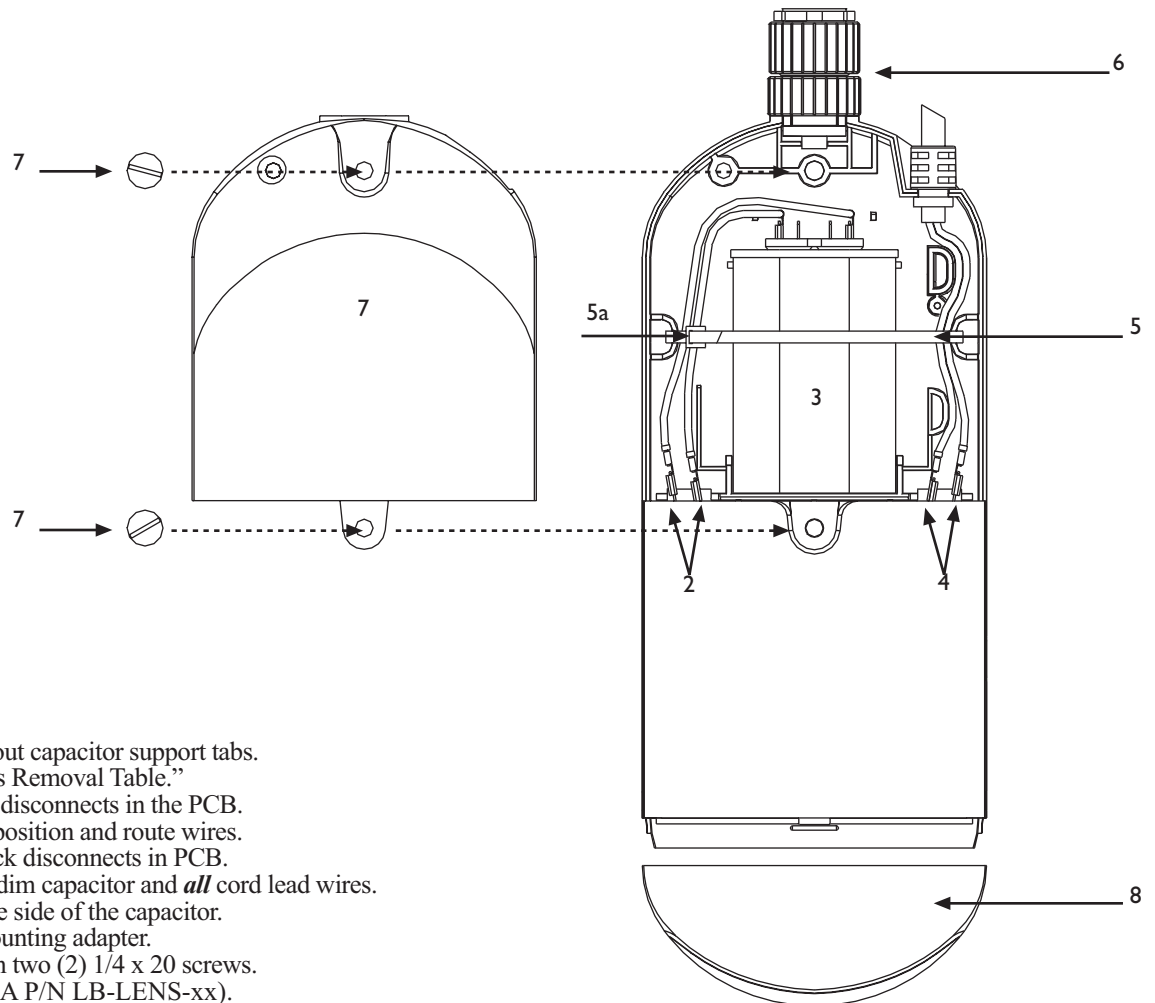

5. Assembly Diagram.

Assembly steps:

1. Using side cutters clip out capacitor support tabs. Refer to “Support Tables Removal Table.”
2. Plug in capacitor quick disconnects in the PCB.
3. Place dim capacitor in position and route wires.
4. Plug in power cord quick disconnects in PCB.
5. Add tie wrap to secure dim capacitor and *all* cord lead wires.
- 5a. Junction must be to the side of the capacitor.
6. Insert 3/4" threaded mounting adapter.
7. Install cover and tighten two (2) 1/4 x 20 screws.
8. Snap on PIR lens (HBA P/N LB-LENS-xx).

6. Mounting Instructions.

IMPORTANT: Mount LightBAT G2 to a 3/4" threaded pipe that is securely mounted. The G2 must not sway or rotate after installation. Failure to meet this requirement will cause false motion sensing and lamps will cycle from low to high power.

Mounting Guidelines:

1. Verify cap value and voltage.
2. Distance between fixture and 3/4" threaded mounting pipe from six (6) inches to six (6) feet.
3. Pipe should be securely mounted.
4. Do not mount below fixture reflector.
5. Do not obstruct view of sensor.
6. Install lock nut on pipe thread.
7. Screw on LightBAT G2 mounting adapter to pipe until tight then lock down nut (6).
8. Remove MYzer Bypass plug and place in Bypass Plug holder located inside of the LightBAT G2 door.
9. Plug in LightBAT G2 power cord.
10. Turn on power.

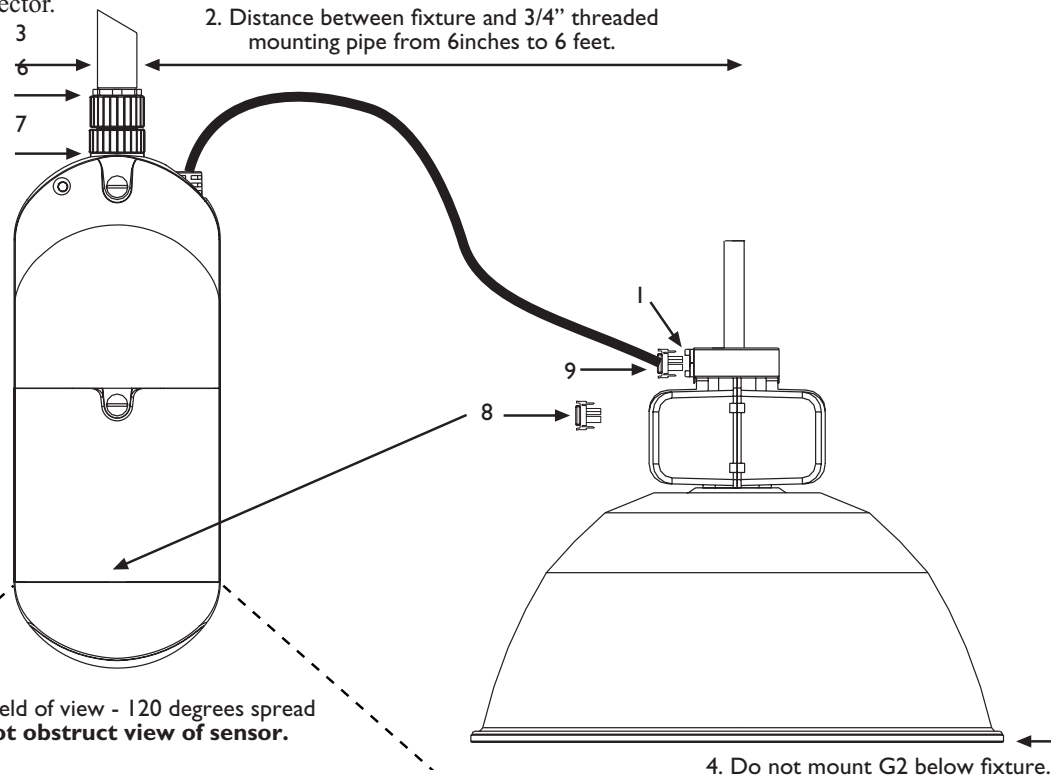

8. Setup and Testing.

1. Wait for lamp to strike and wait for arc to stabilize.
2. Push and hold test button. Lamp will switch low for 1 second then back to bright.
3. Set Dip switches.
4. Verify plumb of pipe with level.
5. Use laser alignment tool (HBA part number: LB-LAT-1) to align sensor down center of aisle.
6. Tighten adapter lock nut.

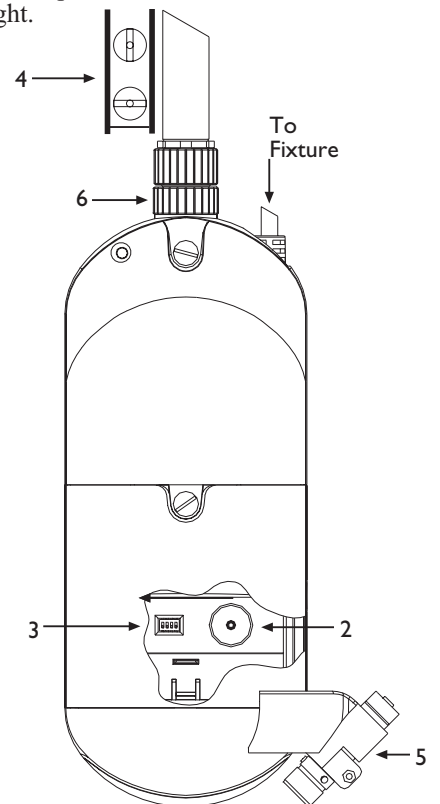

7. Capacitor Support Tab Removal Table

(See opposite side of "Installing and Testing" instructions for Capacitor sizing.)

Capacitor Descriptions	Tabs to remove	Capacitor Dimensions
1 - Oval 2 11/16"	None	1.6 x 2.7 x 2 11/16"
2 - Oval 3 7/8"	B	1.6 x 2.7 x 3 7/8"
3 - Oval 3 7/8"	A, B, C	1.9 x 2.9 x 3 7/8"
4 - Round 45mm x 118mm	A, C, D	1.7 dia. x 4.6"
5 - Round 45mm x 93mm	A, B, C, D	1.7 dia. x 3.6"

9. Dip Switch Setup.

Lights Bright Timer

Controls time interval to low power after area becomes unoccupied. (Hint: Short lights bright timer increases energy savings.)

Force Low (sensor disabled)

Except for lamp warm up periods, fixture will stay at low power regardless of occupancy. Exception is approximately once every 24 hours, lamp is randomly brought to full power for 15 minutes to bring lamp to full temperature.

Low Sensitivity

Lowers PIR motion sensor susceptibility to false tripping due to air currents, heat sources, etc. Only use if lamps switch to full power when no apparent motion is present in the area.

High Sensitivity

Increases PIR motion sensors ability to detect motion. Most applications will use this setting.

Dip Switch Setting Table	0=OFF		X=ON	
Dip Switch Number	1	2	3	4
Lights Bright Timer				
Test (5 sec)	0	0	0	0
1 minute	0	0	X	
2 minutes	0	X	0	
4 minutes	0	X	X	
8 minutes	X	0	0	
32 minutes	X	0	X	
64 minutes	X	X	0	
Sensor				
Force Low (Sensor Disabled)	X	X	X	X
Low Sensitivity				0
High Sensitivity				X

10. Typical Lights Bright Timer Settings:

Area	Timer Setting
Aisles	1, 2, minutes
Manufacturing Work Areas	8 minutes
Receiving and Shipping Areas	4 to 8 minutes
Retail	8 to 32 minutes

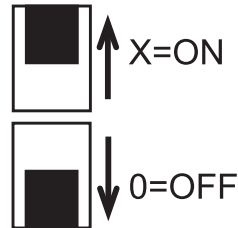

11. LightBAT G2 Troubleshooting Guide.

Lamp Will Not Ignite (Fixture does not work)

1) Lamp will not ignite

- Remove power from the fixture and unplug G2 from fixture
- Re-install the MYzer port shorting plug and apply power to the fixture
- If lamp ignites, fixture is good. Proceed to Step #3.

2) Lamp will not ignite with the MYzer port shorting plug installed (LightBAT G2 is not installed)

- Use normal HID fixture trouble shooting procedures
 - Is power applied to fixture?
 - Check MYzer port wiring
 - Check Capacitor, ballast, lamp & starter if pulse start or HPS
 - Once fixture problem has been solved, re-install LightBAT G2.

3) Lamp will not ignite with the G2 plugged into fixture

- Step #1 troubleshooting was performed and fixture was OK!
- Check power cord and capacitor spade terminal connections. Verify that they are plugged into printed circuit card securely. Loose connections will keep lamp from striking.
- Check capacitor value. If capacitor is too small, there is a slight chance the lamp will not ignite.
- If connections are OK!, Capacitor may be defective:
 - To check for defective capacitor

- Unplug G2 from Fixture

(2) Caution: Discharge capacitor in G2 before servicing.

Short Capacitor terminals with screw driver.

- Unplug capacitor spade terminals from printed circuit card. Using a ohm meter set on highest resistance measurement, connect ohm meter leads to capacitor wires.

- If capacitor is defective or open, the resistance reading should be constant. Replace capacitor. If resistance reading starts out low and then steadily increases for approximately 15 seconds, capacitor is OK

- If capacitor is OK! replace G2.

Lamp Goes Out or Extinguishes

(Fixture works for a while then the lamp goes out)

4) Lamp extinguishes when button is held.

- How the test button works:
 - Test button is intended as a trouble shooting aid. Under normal operating conditions, lamp manufacturers recommend a 12-30 min warm-up before operating lamp at low power.
 - If the lamp goes out when you press the test button, lamp may not be warm enough to stay running while at low power. Wait several minutes longer after the lamp ignites

before pressing again (old lamps will require longer warm up times before pressing the test button)

- iii) Holding the button should force the unit to Low power for one second, back to Bright for 1 second, and then return the unit to the mode of operation it was in before the button push. This is done so the unit still works if the button gets stuck somehow. **Release the button for 2 seconds after holding it so that your subsequent button press will not be ignored.**
- b) If the lamp has warmed up for at least 5 minutes before pushing the test button and the lamp still goes out:
 - i) Lamp is very old and near end of life, replace lamp.
 - ii) Incompatible lamp / ballast combination, replace lamp with correct lamp type.
 - iii) If lamp is OK!, check to make sure capacitor inside G2 is the correct value. Having capacitance values lower than recommended for the ballast inside the fixture is the main cause of lamp problems when operating in low power. Call the factory to verify correct capacitor value. Our tech support staff will need make and model number of ballast, fixture capacitor value and voltage.

5) Lamp extinguishes during operation.

- a) Lamp seems to work Ok for the first 15 minutes (30 minutes for model LB-3) then goes out or extinguishes.
- b) If the lamp is old (nearing end of life) or has been damaged, it can exhibit this symptom. Try swapping with a known good lamp.
- c) Incompatible lamp / ballast combination, replace lamp with correct lamp type.
- d) If lamp is OK!, check to make sure capacitor inside G2 is the correct value. If capacitor in the G2 is too small, the lamp may ignite. However, as soon as the 15 minute (30 minutes for model LB-3) warm up period is complete and the lamp switches to low, the lamp will extinguish.
 - i) Call the factory to verify correct capacitor value.
 - ii) If the G2 cap value is correct, one of the components inside the fixture is the problem
 - (1) Check the ballast, cap and starter if HPS or PSMH.

Lamp Ignites but Does Not Change Power Levels

6) Lamp ignites but never changes from Bright to Low power or Low power to Bright

- a) First, we need to test what in the G2 is working. Push and hold the test button.
 - i) If lamp goes from Bright to Low power for one second, then back to Bright, the unit should be OK and working fine. However, something else is keeping the lights at full bright. Please check troubleshooting instructions for “Lamp Stays in Bright 100% of the Time and never switches to Low Power operation”
 - ii) If lamp goes from Low power to Bright for one second, then back to low power:
 - (1) Check to make sure the lamp went through the full 15 minute (30 minute for model LB-3) warm up cycle before switching to low power.
 - (a) If the lamp did not go to bright during the warm up cycle, the G2 is defective.
 - iii) If the lamp does nothing when the button is pressed and held for 1 second, please check the following:

- (1) Incompatible lamp / ballast combination, replace lamp with correct lamp type.
- (2) If the capacitor in the G2 is too small, the fixture will never transition to Bright and may extinguish at Low power mode. Check the capacitor value in the G2.
- (3) If lamp is OK!, check to make sure capacitor inside G2 is the correct value. Using a capacitor value significantly lower than that recommended for the ballast can cause the G2 not to function properly. Call the factory to verify correct capacitor value.
- (4) If the dim capacitor value is correct, swap the G2 with a known good G2. If the problem goes away, the G2 was defective.

7) Lamp Stays in Bright 100% of the Time and never switches to Low Power operation

- a) First, we need to see if the G2 can switch the lamp to Low Power. Push and hold the test button,
 - i) If the lamp does nothing when the button is pressed, please check the following:
 - (1) Incompatible lamp / ballast combination, replace lamp with correct lamp type.
 - (2) If the capacitor in the G2 is too small, the fixture will never transition to Bright and may extinguish at Low power mode. Check the capacitor value in the G2.
 - (3) If lamp is OK!, check to make sure capacitor inside G2 is the correct value. Using a capacitor value significantly lower than that recommended for the ballast can cause the G2 not to function properly. Call the factory to verify correct capacitor value.
 - (4) If the dim capacitor value is correct, swap the G2 with a known good G2. If the problem goes away, the G2 was defective.
 - ii) If lamp changes from Bright, to Low power for one second and then back to Bright, the PIR motion sensor or if using the external interface port on the back of the G2, one of the connections is keeping the G2 at Bright.
 - (1) Temporarily disable lamp warm up period
 - (a) Set Dip switch #1,2 & 3 to OFF (switches should be in the down position)
 - (b) Set Dip switch #4 to ON (switch should be in the up position)
 - (c) Push and hold the Test button until the lamp changes from Bright, to Low power for one second and then back to Bright.
 - (2) Remove EXTP1 connector on the back of the G2
 - (3) Change Dip switch settings to Force Low
 - (a) Set Dip switch #1, 2, 3 & 4 to ON (all switches should be in the up position)
 - (4) The lamp should switch to low power. If the lamp does not switch to Low Power, the G2 is defective and needs to be replaced.
 - (5) If the lamp does switch to low power, the PIR motion sensor is the problem. Please refer to “PIR Motion Sensor is Keeping the Lamp at Bright”

Fixture Lights up OK! But the G2 does not work as expected

***Run tests #6 & #7 in “Lamp Ignites but Does Not Change Power Levels” before running any tests in this section.**

8) PIR Motion Sensor is Keeping the Lamp at Bright.

- a) **Important:** Installation check list, make sure that these problems do not exist

- i) The G2 needs to be rigidly mounted and not allowed to move, swing, sway or rotate.
- ii) The G2 supporting member must not be affected by vibration from machinery or equipment.
- iii) Strong air currents and air from HVAC units will cause the PIR motion sensor to false trip and keep the lamp at Bright.
- iv) Moving or vibrating objects in the PIR sensors field of view will also cause the PIR motion sensor to false trip and keep the lamp at Bright.
 - a) High and Low PIR sensitivity settings are available on the G2. At High sensitivity setting, it is very important that none of the conditions exist in (a) above.
 - b) At longer Lights Bright Timer settings (30 to 60 minutes), it is very important that none of the conditions exist in (a) above.
 - c) Push and hold the test button.
 - i) If lamp changes from Bright, to Low power for one second and then back to Bright, continue on with this test
 - ii) If the lamp does nothing, refer to “Lamp ignites but never changes from Bright to Low power or Low power to Bright” earlier in this trouble shooting section.
 - d) Temporarily disable lamp warm up period
 - (1) Set Dip switch #1,2 & 3 to OFF (switches should be in the down position)
 - (2) Set Dip switch #4 to ON (switch should be in the up position)
 - (3) Push and hold the Test button until the lamp changes from Bright, to Low power for one second and then back to Bright.
 - e) Set Dip switch timer settings: #1, 2 & 3 to OFF, 5 second Lights Bright Timer (Switches should be in the down position)
 - f) Back away from the sensor and do not move. Lamp should go to Low Power in 5 to 10 seconds.
 - i) If lamp does not switch to Low Power after 30 seconds
 - (1) Repeat steps (a) through (d) above and try again.
 - (2) If this does not work, the G2 is defective.
 - ii) If the lamp switches to Low Power after 30 seconds
 - (1) Sweep your hand slowly 18” below the PIR lens, the lamp should cycle to Bright.
 - (2) After 5 to 10 seconds the lamp will switch back to Low Power
 - g) Perform a walk test and see if the problem went away
 - i) Verify dip switch timer settings: #1, 2 & 3 to OFF, 5 second Lights Bright Timer (switches should be in the down position)
 - ii) Verify dip switch Sensitivity setting: #4 to OFF, Low sensitivity setting
 - iii) Stay outside the PIR sensor coverage area and wait for Lamp to switch to Low Power
 - (1) If the lamp stays Bright, air flow, vibration, a moving G2 unit or some other motion source is causing the PIR sensor to keep the lamp at Bright.
 - iv) Now walk into the coverage area, and the lamp should switch to Bright.
 - v) If sensing performance is acceptable, set Lights Bright Timer for the application and you are finished.
 - vi) If sensing performance is not acceptable, please refer

to “Low sensor performance or sensor does not detect motion in expected area”

9) Lights false from Low Power to Bright for no apparent reason

- a) **Important:** Installation check list, make sure that these problems do not exist
 - i) The G2 needs to be rigidly mounted and not allowed to move, swing, sway or rotate.
 - ii) The G2 supporting member must not be affected by vibration from machinery or equipment.
 - iii) Strong air currents and air from HVAC units will cause the PIR motion sensor to false trip and keep the lamp at Bright.
- b) High and Low PIR sensitivity settings are available on the G2. At High sensitivity setting, it is very important that none of the conditions exist in (a) above. Do not go to the next step until you are absolutely sure.
- c) If the problem still exists, try setting Sensitivity dip switch #4 to OFF, Low sensitivity setting.
- d) If this does not solve the problem, verify the orientation of the coverage pattern using the Laser Alignment tool (LB-LAT-1) and review the lens coverage pattern. You must know the detection coverage pattern of the PIR motion sensor. In this detection coverage area, make sure that:
 - i) No objects are moving, rotating or swaying
 - ii) No air flow is present
 - iii) No heat sources in coverage pattern are rapidly changing
 - iv) If none of these problems exist, the G2 is defective.

10) Low Sensor Performance or Sensor doesn't detect motion in expected area.

- a) There is a different color for each lens pattern. Verify that the lens color matches the pattern that you want and the mounting height is within the maximum recommended mounting height.
- b) Verify that the lens does not have a mask installed.
- c) Verify the orientation of the coverage pattern using the Laser Tool (LB-LAT-1).
- d) Measure the floor temperature. If the floor feels warm (~85F) it may be difficult for the sensor to detect human motion. Higher sensitivity is required or a lens with a smaller coverage pattern. A change in temperature within the detection zone is needed for the sensor to work properly.
- e) Set the dip switch to High sensitivity. (#4 to ON, or in the up position)
- f) If the performance is still not acceptable call HBA to discuss different Lens and layout options.

11) Fixture stays in Low power mode

- a) Verify that the unit is operating in Low Power by holding the test button. The unit should go Bright for 1 second and then back to Low Power when the test button is held.
- b) Check dip switches to make sure that #1, 2, 3, & 4 are not all ON (switches in the UP position). This forces the lamp to remain in Low Power after warm-up.
- c) Remove EXTP1 connector on the back of the G2 (Only if option EXTP1 was ordered with the G2)
- d) Sweep your hand slowly 18” below the PIR lens, the lamp should cycle to Bright.
- e) If the G2 does not respond, replace the G2 or call HBA for assistance.

12. Ballast Wiring Diagrams.

Standard High Pressure Sodium or Pulse Start Metal Halide Fixture Wiring

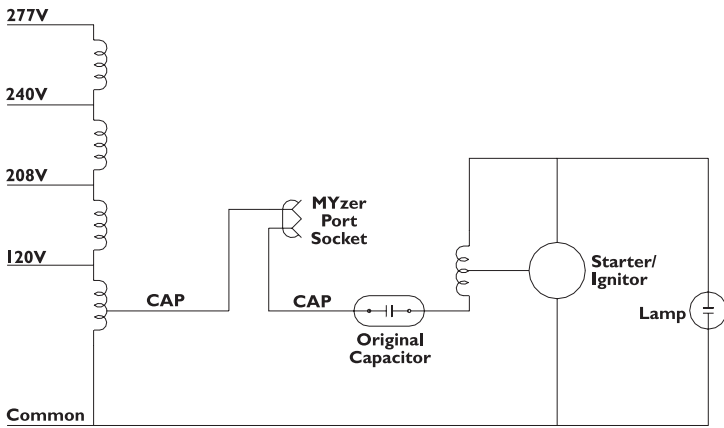

Metal Halide Fixture Wiring

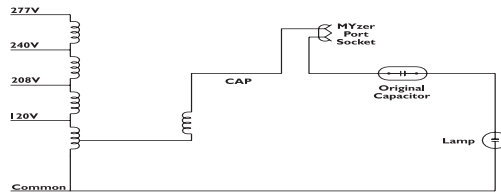

13. Capacitor Templates. (ratio 1:1)

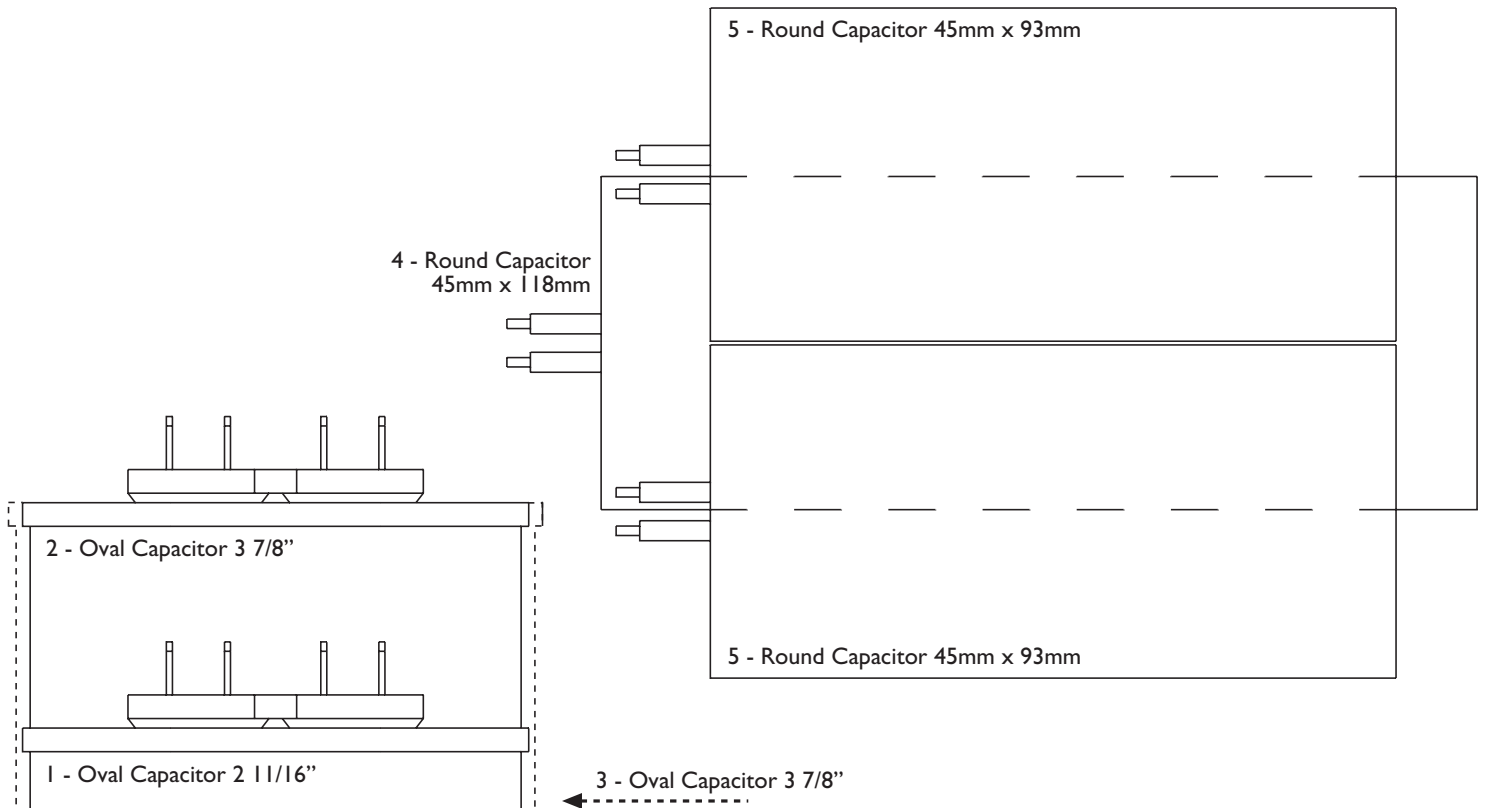

Capacitor Support Tab Removal Table

(See opposite side of "Installing and Testing" instructions for Capacitor sizing.)

Capacitor Descriptions	Tabs to remove	Capacitor Dimensions
1 - Oval 2 11/16"	None	1.6 x 2.7 x 2 11/16"
2 - Oval 3 7/8"	B	1.6 x 2.7 x 3 7/8"
3 - Oval 3 7/8"	A, B, C	1.9 x 2.9 x 3 7/8"
4 - Round 45mm x 118mm	A, C, D	1.7 dia. x 4.6"
5 - Round 45mm x 93mm	A, B, C, D	1.7 dia. x 3.6"